



## **DATA SHEET**

### **LIQUID CRYSTAL DISPLAY MODULE**

**RC162001YFHLYB**

**Customer's No.: XXXXXX**

**SPECIFICATIONS FOR LIQUID CRYSTAL DISPLAY MODULE  
MODEL NO: RC162001YFHLYB**

**CONTENTS**

1. SCOPE	-----	3
2. PRODUCT SPECIFICATIONS	-----	3
2.1 General	-----	3
2.2 Mechanical Characteristics	-----	4
2.3 Absolute Maximum Ratings	-----	5
2.4 Electrical Characteristics	-----	5
2.5 Absolute maximum ratings	-----	6
2.6 Optical Characteristics	-----	6
2.7 LED Back-light Characteristics	-----	9
3. RELIABILITY	-----	10
4. OPERATING INSTRUCTIONS	-----	11
4.1 Input signal Function	-----	11
4.2 Voltage Generator Circuit	-----	11
4.3 Circuit Block Diagram	-----	12
4.4 Timing Characteristics	-----	13
4.5 Instruction table	-----	14
4.6 Font table	-----	15
5. NOTES	-----	16
6. OPERATION PRECAUTIONS	-----	16
7. LCM Dimension	-----	17

**SPECIFICATIONS FOR LIQUID CRYSTAL DISPLAY MODULE  
MODEL NO: RC162001YFHLYB**

## **1. SCOPE**

The R162001YFHLYB, dot-matrix LCD unit of a 5 x 7- dot 16-character 2-line dot-matrix LCD panel, LCD driver, controller LSI and yellow green back-light LED fabricated on a single PCB. Incorporating mask ROM-based character generator and display data RAM in the controller LSI, the unit can efficiently display the desired characters under microprocessor control.

## **2. PRODUCT SPECIFICATIONS**

### **2.1 General**

- The LCD of the unit is STN (Yellow-Green) Transflective , Wide temperature type.
- Low power consumption with the dot-matrix LCD panel and CMOS LSI.
- Thin, lightweight design permits easy installation in a variety of equipment.
- Allowing for being connected at general-purpose CMOS signal level, the unit can be easily interfaced to a microprocessor with common 4-bit and 8-bit parallel inputs and outputs.
- Multiplexing driving : 1/16duty, 1/4bias, 6 o'clock
- Built-in character generator ROM and RAM, and display data RAM:
  - Character generator ROM
    - 225 different 5 x 7 dot-matrix character patterns (Alphanumeric and symbols)
  - Character generator RAM
    - 8 different user programmed 5 x 7 dot-matrix patterns
  - Display data RAM
    - 80 x 8 bits
- Numerous instructions
  - Display clear, Cursor home, Display ON/OFF, Cursor ON/OFF, Blink character, Cursor shift, Display shift

**SPECIFICATIONS FOR LIQUID CRYSTAL DISPLAY MODULE  
MODEL NO: RC162001YFHLYB**

2.2 Mechanical Characteristics

<b>Item</b>	<b>Characteristic</b>
Number of Characters	16 × 2
Dot dimensions(mm)	0.5 × 0.55
Dot spacing (mm)	0.07
Character Size (mm)	2.78 × 4.89
Module dimensions (Horizontal × Vertical × Thickness, mm)	80.0 × 36.0 × 14.5 max.
Viewing area (Horizontal × Vertical, mm)	62.5 × 16.1

**SPECIFICATIONS FOR LIQUID CRYSTAL DISPLAY MODULE**  
**MODEL NO: RC162001YFHLYB**

2.3 Absolute Maximum Ratings (Without LED back-light)

Characteristic	Symbol	Unit	Value
Power Supply Voltage (1)	$V_{DD}$	V	-0.3~+0.7
Power Supply Voltage (2)	$V_{LCD}$	V	$V_{DD}-15.0\sim V_{DD}+0.3$
Power Supply Voltage	$V_{IN}$	V	-0.3~ $V_{DD}+0.3$

2.4 Electrical Characteristics (Without LED back-light)

Characteristic	Symbol	Condition	Min.	Typ.	Max.	Unit
Operating Voltage	$V_{DD}$	--	4.5	--	5.5	V
Supply Current	$I_{DD}$	Internal oscillation or external clock ( $V_{DD}=5.0V, f_{OSC}=270kHz$ )	--	0.35	0.6	mA
Input Voltage(1) (except OSC1)	$V_{IH1}$	--	2.2	--	$V_{DD}$	V
	$V_{IL1}$	--	-0.3	--	0.6	
Input Voltage(2) (OSC1)	$V_{IH2}$	--	$V_{DD}-0.1$	--	$V_{DD}$	V
	$V_{IL2}$	--	-0.2	--	1.0	
Output Voltage(1) (DB0 to DB7)	$V_{OH1}$	$I_{OH}=-0.205mA$	2.4	--	--	V
	$V_{OL1}$	$I_{OL}=1.2mA$	--	--	0.4	
Output Voltage(2) (DB0 to DB7)	$V_{OH2}$	$I_O=-40\mu A$	$0.9V_{DD}$	--	--	V
	$V_{OL2}$	$I_O=40\mu A$	--	--	$0.1V_{DD}$	
Voltage Drop	$V_{dCOM}$	$I_O=0.1mA$	--	--	1	V
	$V_{dSEG}$		--	--	1	
Input Leakage Current	$I_{IKG}$	$V_{IN}=0V$ to $V_{DD}$	-1	--	1	$\mu A$
Input Low Current	$I_{IL}$	$V_{IN}=0V, V_{DD}=5V$ (Pull Up)	-50	-125	-250	
Internal Clock (external Rf)	$f_{OSC1}$	$R_f=91k \pm 2\%$ ( $V_{DD}=5V$ )	190	270	350	kHz
External Clock	$f_{OSC}$	--	125	270	410	kHz
	duty		45	50	55	%
	$t_R, t_F$		--	--	0.2	$\mu S$
LCD Driving Voltage	$V_{LCD}$	$V_{DD}-V_5$ (1/5, 1/4 Bias)	3.0	--	13.0	V

**SPECIFICATIONS FOR LIQUID CRYSTAL DISPLAY MODULE**  
**MODEL NO: RC162001YFHLYB**

2.5 Optical Characteristics

Absolute maximum ratings

Item	Symbol	Rating	Unit	Remarks
Storage temperature range	Tst	-30~70	°C	No condensation
Operating temperature range	Top	-20~70	°C	No condensation
Maximum AC applied voltage	VAC	10	V	Less than 1 hour
Maximum DC applied voltage	VDC	50	Mv	--

2.6 Optical Characteristics

1/16 duty, 1/4 bias, Vopr=4.20V

Item	Symbol	Temp.	Min.	Typ.	Max.	Unit
Driving voltage	Vop	0 °C	4.35	4.45	4.75	V
		25 °C	4.10	4.20	4.50	
		50 °C	3.65	3.75	4.10	
Contrast	Cr	25 °C	4	7	--	--
Frame freq.	F	--	--	64	--	Hz
Viewing angle*	$\theta_1$	25 °C	--	50	--	deg.
	$\theta_2$		--	130	--	
Response time	t <sub>on</sub>	25 °C	--	100	200	ms
	t <sub>off</sub>		--	210	340	

**SPECIFICATIONS FOR LIQUID CRYSTAL DISPLAY MODULE  
MODEL NO: RC162001YFHLYB**

2.6.1 Definition of optical characteristics

\* Definition of angles  $\phi$  and  $\theta$

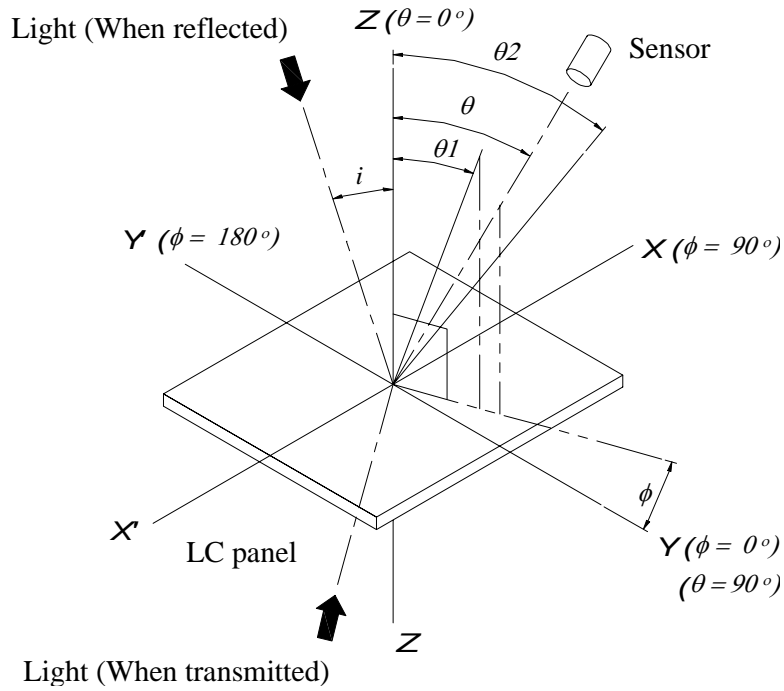

\*Definition of contrast C

$$C = \frac{B1}{B2} = \frac{\text{Brightness of selected portion}}{\text{Brightness of unselected portion}}$$

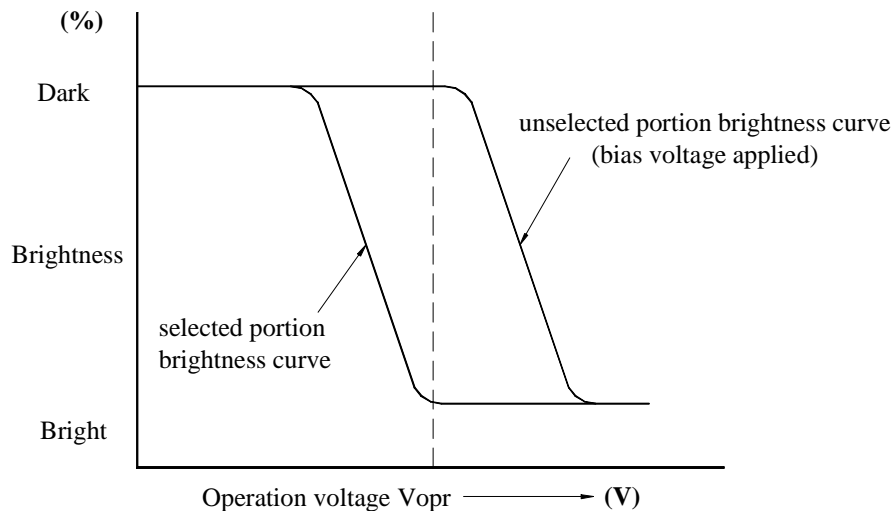

**SPECIFICATIONS FOR LIQUID CRYSTAL DISPLAY MODULE  
MODEL NO: RC162001YFHLYB**

\* Definition of viewing angles  $\theta_1$  and  $\theta_2$

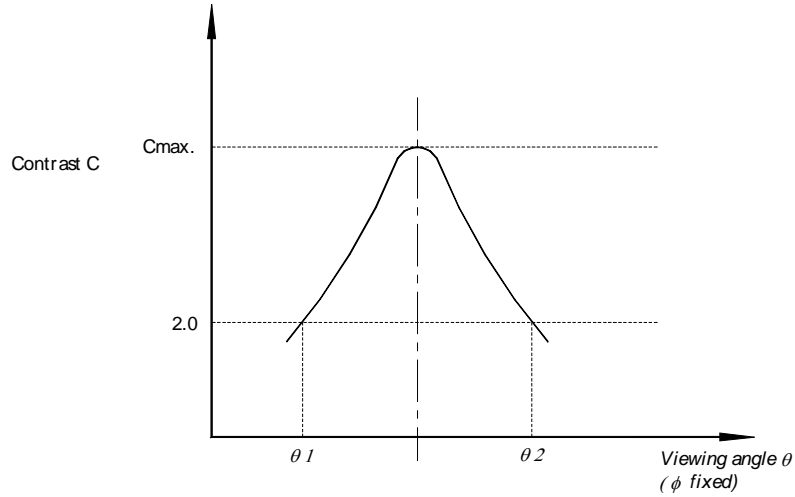

Note : Optimum vision with the naked eye and viewing angle  $\theta$  at  $C_{max}$  above are not always the same.

\* Definition of response time

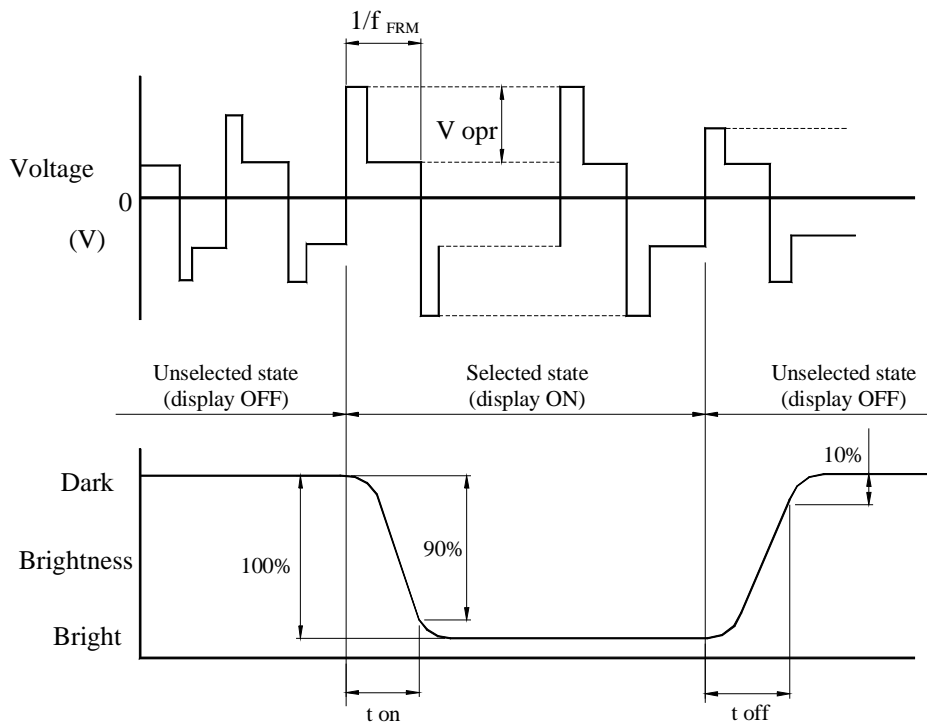

$V_{opr}$  : Operating voltage (V)

$t_{on}$  : Response time (rise) (ms)

$f_{frm}$  : Frame frequency (Hz)

$t_{off}$  : Response time (fall) (ms)

**SPECIFICATIONS FOR LIQUID CRYSTAL DISPLAY MODULE  
MODEL NO: RC162001YFHLYB**

2.7 LED Back-light Characteristics

2.7.1 Absolute maximum ratings

Ta = 25°C

Item	Symbol	Condition	Min.	Typ.	Max.	Unit
Forward voltage	$V_f$	If=120Ma, Yellow Green	3.9	4.1	4.4	V
*Luminous Intensity	$I_v$	If=120Ma, Yellow Green	--	350	--	LUX
Peak Emission Wavelength	$\lambda_P$	If=20Ma, Yellow Green	--	573	--	nm
Spectrum Radiation Bandwidth	$\Delta\lambda$	If=20Ma, Yellow Green	--	30	--	nm
Reverse Current	$I_R$	VR=8V, Yellow Green	--	--	0.12	Ma

Note: \* Measured at the bare LED back-light unit.

2.7.2 LED Maximum Operating Range

Item	Symbol	Yellow Green	Unit
Power Dissipation	$P_{AD}$	1.144	W
Forward Current	$I_F$	260	Ma
Reverse Voltage	$V_R$	8	V

**SPECIFICATIONS FOR LIQUID CRYSTAL DISPLAY MODULE  
MODEL NO: RC162001YFHLYB**

**3. RELIABILITY**

3.1 Reliability

Test item	Test condition	Evaluation and assessment
Operation at high temperature and humidity	40 °C±2 °C 90%RH for 500hours	No abnormalities in functions* and appearance**
Operation at high temperature	60 °C±2 °C for 500 hours	No abnormalities in functions* and appearance**
Heat shock	-20± ~ +60 °C Left for 1 hour at each temperature, transition time 5 min, repeated 10times	No abnormalities in functions* and appearance**
Low temperature	-20±2 °C for 500 hours	No abnormalities in functions* and appearance**
Vibration	Sweep for 1 min at 10 Hz, 55Hz, 10Hz, amplitude 1.5mm 2 hrs each in the X, Y and Z directions	No abnormalities in functions* and appearance**
Drop shock	Dropped onto a board from a height of 10cm	No abnormalities in functions* and appearance**

\* Dissipation current, contrast and display functions

\*\* Polarizing filter deterioration, other appearance defects

3.2 Liquid crystal panel service life

100,000 hours minimum at 25 °C±10 °C

3.3 Definition of panel service life

- Contrast becomes 30% of initial value
- Current consumption becomes three times higher than initial value
- Remarkable alignment deterioration occurs in LCD cell layer
- Unusual operation occurs in display functions

**SPECIFICATIONS FOR LIQUID CRYSTAL DISPLAY MODULE  
MODEL NO: RC162001YFHLYB**

**4. OPERATING INSTRUCTIONS**

4.1 Input signal Function

NO.	Symbol	Function
1	VSS	Ground (0V)
2	VDD	Power supply for Logic circuit
3	V0	Power Supply for Driving the LCD
4	RS	Data / Instruction select
5	R/W	Read / Write select
6	E	Enable signal
7-14	DB0-DB7	Data Bus line
15	LED A	Power supply for LED
16	LED K	Power supply for LED

4.2 Voltage Generator Circuit

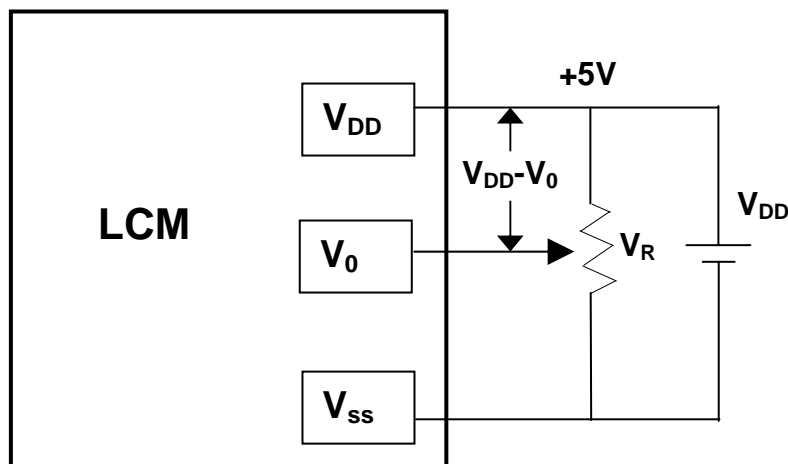

$V_{DD}-V_0$  : LCD Driving Voltage  
 $V_R$  : 10K~20K

**SPECIFICATIONS FOR LIQUID CRYSTAL DISPLAY MODULE  
MODEL NO: RC162001YFHLYB**

4.3 Circuit Block Diagram

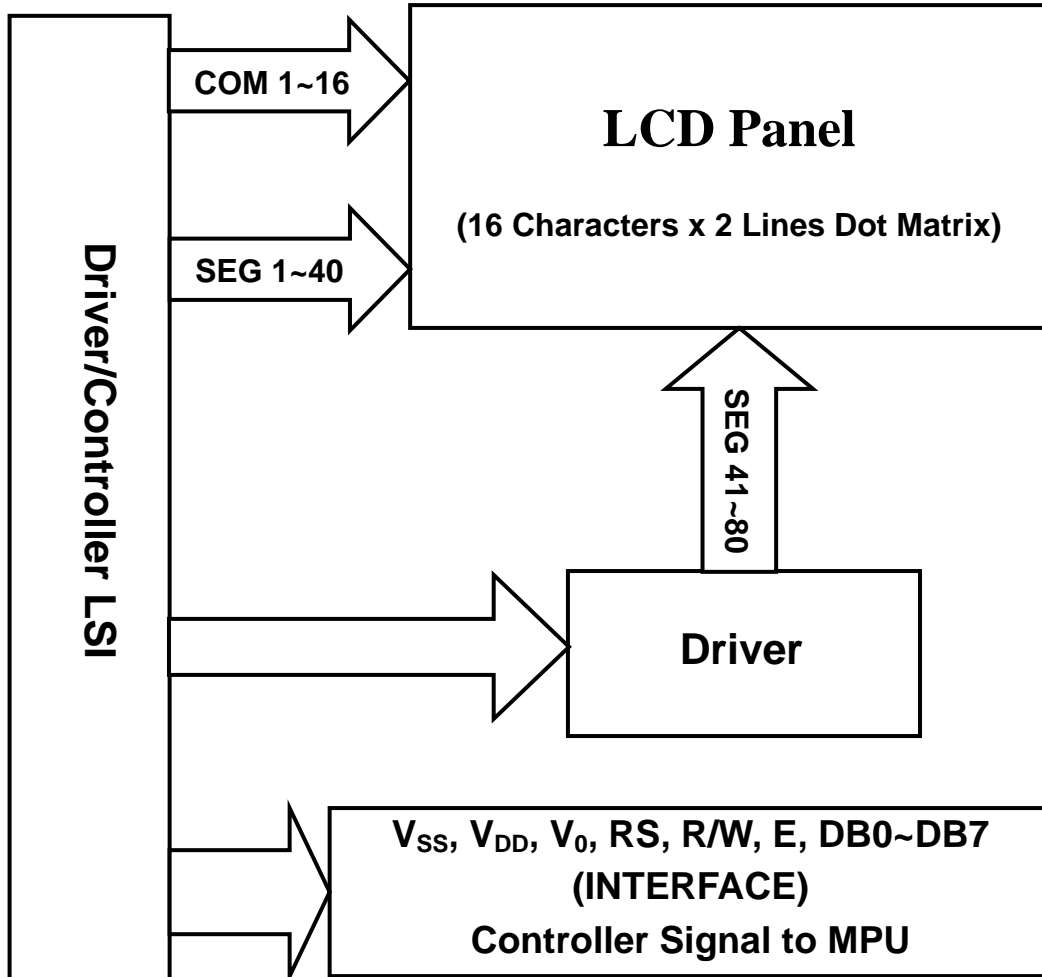

**SPECIFICATIONS FOR LIQUID CRYSTAL DISPLAY MODULE  
MODEL NO: RC162001YFHLYB**

4.4 Timing Characteristics

Mode	Characteristic	Symbol	Min.	Typ.	Max.	Unit
Write Mode (Refer to Fig-6)	E Cycle Time	$t_c$	500	-	-	ns
	E Rise / Fall Time	$t_{r,f}$	-	-	20	
	E Pulse Width (High, Low)	$t_w$	230	-	-	
	R/W and RS Setup Time	$t_{su1}$	40	-	-	
	R/W and RS Hold Time	$t_{H1}$	10	-	-	
	Data Setup Time	$t_{su2}$	80	-	-	
	Data Hold Time	$t_{H2}$	10	-	-	
Read Mode (Refer to Fig-7)	E Cycle Time	$t_c$	500	-	-	ns
	E Rise / Fall Time	$t_{r,f}$	-	-	20	
	E Pulse Width (High, Low)	$t_w$	230	-	-	
	R/W and RS Setup Time	$t_{su}$	40	-	-	
	R/W and RS Hold Time	$t_H$	10	-	-	
	Data Output Delay Time	$t_D$	-	-	120	
	Data Hold Time	$t_{DH}$	5	-	-	

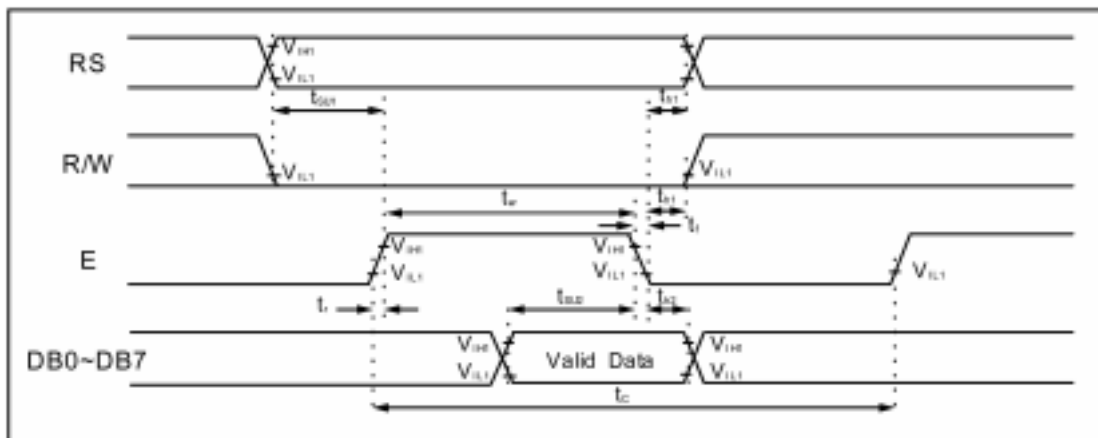

Write Mode Timing Diagram

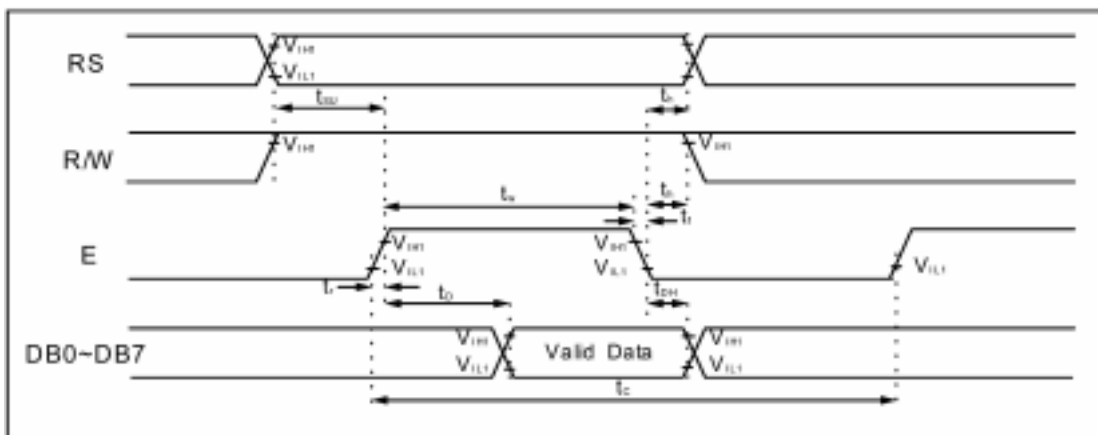

Read Mode Timing Diagram

**SPECIFICATIONS FOR LIQUID CRYSTAL DISPLAY MODULE  
MODEL NO: RC162001YFHLYB**

4.5 Instruction table

Instruction	Instruction Code											Description	Execution time (fosc= 270 kHz)
	RS	R/W	DB7	DB6	DB5	DB4	DB3	DB2	DB1	DB0			
Clear Display	0	0	0	0	0	0	0	0	0	0	1	Write "20H" to DDRAM and set DDRAM address to "00H" from AC	1.53 ms
Return Home	0	0	0	0	0	0	0	0	0	1	-	Set DDRAM address to "00H" from AC and return cursor to its original position if shifted. The contents of DDRAM are not changed.	1.53 ms
Entry Mode Set	0	0	0	0	0	0	0	0	1	I/D	SH	Assign cursor moving direction and enable the shift of entire display.	39 μs
Display ON/OFF Control	0	0	0	0	0	0	0	1	D	C	B	Set display(D), cursor(C), and blinking of cursor(B) on/off control bit.	39 μs
Cursor or Display Shift	0	0	0	0	0	0	1	S/C	R/L	-	-	Set cursor moving and display shift control bit, and the direction, without changing of DDRAM data.	39 μs
Function Set	0	0	0	0	0	1	DL	N	F	-	-	Set interface data length (DL: 8-bit/4-bit), numbers of display line (N: 2-line/1-line) and, display font type (F:5×11dots/5×8 dots)	39 μs
Set CGRAM Address	0	0	0	1	AC5	AC4	AC3	AC2	AC1	AC0		Set CGRAM address in address counter.	39 μs
Set DDRAM Address	0	0	1	AC6	AC5	AC4	AC3	AC2	AC1	AC0		Set DDRAM address in address counter.	39 μs
Read Busy Flag and Address	0	1	BF	AC6	AC5	AC4	AC3	AC2	AC1	AC0		Whether during internal operation or not can be known by reading BF. The contents of address counter can also be read.	0 μs
Write Data to RAM	1	0	D7	D6	D5	D4	D3	D2	D1	D0		Write data into internal RAM (DDRAM/CGRAM).	43 μs
Read Data from RAM	1	1	D7	D6	D5	D4	D3	D2	D1	D0		Read data from internal RAM (DDRAM/CGRAM).	43 μs

\* \*-: don't care

SPECIFICATIONS FOR LIQUID CRYSTAL DISPLAY MODULE  
MODEL NO: RC162001YFHLYB

4.6 Font table

Upper 4bit Lower 4bit	LLLL	LLHL	LLHH	LHLL	LHLH	LHHL	LHHH	HLLL	HLLH	HLHL	HLHH	HOHL	HOHL	HOHL	HOHL
LLLL	CG RAM (1)		0	1	2	3	4	5	6	7	8	9	A	B	C
LLLH	(2)	!	1	A	Q	a	9			.	2	3	4	5	6
LLHL	(3)	"	2	B	R	b	r			7	8	9	A	B	C
LLHH	(4)	#	3	C	S	c	s			0	1	2	3	4	5
LHLL	(5)	\$	4	D	T	d	t			6	7	8	9	A	B
LHLH	(6)	%	5	E	U	e	u			.	0	1	2	3	4
LHHL	(7)	&	6	F	V	f	v			3	4	5	6	7	8
LHHH	(8)	'	7	G	W	g	w			4	5	6	7	8	9
HLLL	(1)	(	8	H	X	h	x			5	6	7	8	9	A
HLLH	(2)	)	9	I	Y	i	y			6	7	8	9	A	B
HLHL	(3)	*	:	J	Z	j	z			7	8	9	A	B	C
HLHH	(4)	+	;	K	[	k	[			8	9	A	B	C	D
HOHL	(5)	,	<	L	]	l	]			9	A	B	C	D	E
HHLH	(6)	-	=	M	^	m	^			A	B	C	D	E	F
HHHL	(7)	.	>	N	_	n	_			B	C	D	E	F	G
HHHH	(8)	/	?	O	`	o	`			C	D	E	F	G	H

**SPECIFICATIONS FOR LIQUID CRYSTAL DISPLAY MODULE  
MODEL NO: RC162001YFHLYB**

## **5. NOTES**

### Safety

- If the LCD panel breaks, be careful not to get the liquid crystal in your mouth. If the liquid crystal touches your skin or clothes, wash it off immediately using soap and plenty of water.

### Handling

- Avoid static electricity as this can damage the CMOS LSI.
- The LCD panel is plate glass; do not hit or crush it.
- Do not remove the panel or frame from the module.
- The polarizing plate of the display is very fragile; handle it very carefully

### Mounting and Design

- Mount the module by using the specified mounting part and holes.
- To protect the module from external pressure, leave a small gap by placing transparent plates (e.g. acrylic or glass ) on the display surface, frame, and polarizing plate
- Design the system so that no input signal is given unless the power-supply voltage is applied.
- Keep the module dry. Avoid condensation, otherwise the transparent electrodes may break.

### Storage

- Store the module in a dark place where the temperature is  $25^{\circ}\text{C}\pm 10^{\circ}\text{C}$  and the humidity below 65% RH.
- Do not store the module near organic solvents or corrosive gases.
- Do not crush, shake, or jolt the module (including accessories).

### Cleaning

- Do not wipe the polarizing plate with a dry cloth, as it may scratch the surface.
- Wipe the module gently with soft cloth soaked with a petroleum benzine.
- Do not use ketonic solvents (ketone and acetone) or aromatic solvents (toluene and xylene), as they may damage the polarizing plate.

## **6. OPERATION PRECAUTIONS**

Any changes that need to be made in this specification or any problems arising from it will be dealt with quickly by discussion between both companies.

